

BARIX X8

I/O to RS-485 Modbus converter
for commercial interfacing,
control and home automation
applications

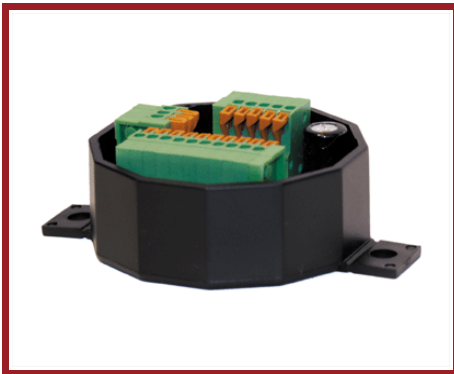

PRODUCT MANUAL

Version: 1.5

Date: 10/26/2006

For Firmware Version 6

Table of Contents

Introduction..... 1

Hardware..... 2

| | |
|--------------------------------|---|
| Case..... | 2 |
| Connectors..... | 2 |
| Power supply requirements..... | 2 |
| Inputs..... | 2 |
| Outputs..... | 2 |
| 5VDC output..... | 3 |
| RS-485..... | 3 |
| LED Indicators..... | 3 |
| Configuration Memory..... | 3 |

Connectors..... 4

| | |
|-----------------------------------|---|
| Connector Pin out overview..... | 4 |
| J1 Pin out I/O..... | 4 |
| J3 Pin out Power/RS-485..... | 5 |
| J4 Pin out GND/Shield Jumper..... | 5 |
| J5 Pin out Shield..... | 6 |
| LED I..4 Functions..... | 6 |

Protocol support..... 7

| | |
|----------------------------------|----|
| General..... | 7 |
| Supported Standard Commands..... | 7 |
| Special Commands..... | 7 |
| Exceptions..... | 8 |
| Command 68..... | 8 |
| Command 69..... | 9 |
| Command 70..... | 9 |
| Command 71..... | 10 |

| | |
|---------------------------|-----------|
| Configuration..... | 11 |
| Default Parameters..... | 11 |

| | |
|-----------------------------------|-----------|
| Connecting I/O..... | 12 |
| Contacts on inputs..... | 12 |
| LEDs on outputs..... | 12 |
| TTL devices on I/O..... | 13 |
| WIEGAND device..... | 13 |
| Barix TS Temperature Sensors..... | 15 |

| | |
|---|-----------|
| Connecting a Barix Barionet controller.. | 16 |
| Power wiring..... | 16 |
| RS-485 wiring..... | 16 |
| Reference wire..... | 16 |
| RS-485 termination..... | 16 |

| | |
|---------------------------------|-----------|
| Modbus Register Map..... | 17 |
| Live I/O..... | 17 |
| Configuration Data..... | 18 |
| Complete Register Map..... | 20 |
| Complete Coils Map..... | 21 |

| | |
|---|-----------|
| Technical specifications..... | 23 |
| CPU..... | 23 |
| I/Os..... | 23 |
| 5VDC output..... | 23 |
| I/O, RS-485/Power, shield Connectors..... | 23 |
| Host Interface..... | 23 |
| Power Supply Requirements..... | 23 |
| LED Indicators..... | 23 |
| Case..... | 23 |
| Misc..... | 23 |
| Conformity..... | 23 |

Introduction

The BARIX X8 is an I/O to RS-485 Modbus converter for commercial interfacing, control and home automation applications.

Using the industry standard Modbus protocol over 2-wire RS-485

the device can be controlled from any Modbus capable master.

Eight independent configurable inputs/outputs allow the use of the BARIX X8 in a wide range of I/O applications:

- General I/O to RS-485 converter (inputs and outputs)
- Up to eight push buttons (inputs) or LED's for status display
- Local analog voltage reading (0-5VDC, 8 inputs)
- Local temperature (up to 8 Barix TS digital sensors)
- WIEGAND reader to RS-485 converter (2 inputs for D0 and D1, other 6 I/Os usable with standard functions)

The device is configured via the serial interface using standard Modbus read/writes. If the device ID is unknown, a special command is available, which can be sent via broadcast and uses the serial number of the device to send it new configuration info.

If the address of the device is not known, it can be reset to default parameters (see chapter "Configuration").

The protocol supported is Modbus/RTU at 19200 (default) and 9600 Baud, with even (default) or no parity.

Hardware

| | |
|----------------------------------|---|
| Case | <p>The BARIX X8 I/O to RS-485 Modbus converter comes in an open plastic case. Two mounting brackets with 5mm holes allow mounting on surfaces but can be cut off (predetermined cut line) if not used.</p> |
| Connectors | <p>The Power/RS-485, I/O (I/O, 5Vout,GND) and cable shield are available on 3 spring contact connector blocks for wires AWG28 - AWG16 / 0.08 - 1.3 mm²</p> |
| Power supply requirements | <p>The BARIX X8 is equipped with a universal power input and accepts both AC and DC voltage. The AC supply range is 12 to 24 Volts and 9 to 30 Volts when powered by a DC power supply.</p> <p>A voltage regulator controls the internally needed operating voltage of 5VDC. The BARIX X8 consumes with all outputs activated 1 Watt max. The BARIX X8 is reverse polarity protected.</p> <p>Attention: When powering the BARIX X8 and other BARIX devices (Barionet, IO12, R6), connected over RS-485, using a single power supply only a DC type power supply can be used as the RS-485 interfaces are not completely potential free.</p> |
| Inputs | <p>All I/O pins are directly connected to the CPU and the absolute rating is TTL level (0 to 5VDC). When used as digital input the signal is filtered (48 milliseconds period for debouncing) to allow for direct connection of buttons or contact closures.</p> <p>The analog value of each input is digitalized every 16 milliseconds (sampling rate 62.5 Hz) with a resolution of 10bit (0 to 1023) and is stored in separate Modbus registers.</p> <p>On each input a BARIX TS digital temperature sensor can be attached for precise temperature reading.</p> |

Outputs

All I/O pins are connected to the CPU directly and the absolute rating is TTL level (0..5VDC). Each output can sink or source up to 20mA. See "5VDC output" for total current limitations !

5VDC output

A regulated 5VDC output is available to provide power to small devices, LEDs etc. To prevent overheating of the voltage regulator the sourcing current of 5VDC and all used outputs combined should not exceed 24mA @ 30VDC Vin, 32mA @ 24VDC Vin, 85mA @ 12VDC Vin or 100mA@ Vin <= 11VDC.

RS-485

The BARIX X8 has an RS-485 host interface, available on a spring contact connector block.

Besides "A" and "B" signals for the differential, bidirectional bus signal, a third connection is available, commonly referred to as "reference ground". This signal is internally tied to signal ground via a 100 Ohm series resistor.

Termination resistors are NOT provided on-board. A termination resistor may be added at each end of the RS-485 bus if required.

The BARIX X8, as well as other Barix I/O extension units, feature soft pull-up (B) and pull down (A) 10kOhm resistors, which force the inactive bus to a relatively high impedance, idle condition.

Both A and B line signals are heavily protected against ESD (Electrostatic Discharge).

Supported interface configurations are

19200 baud, 8bit, even parity, 1 stop bit (**default**)

19200 baud, 8bit, no parity, 1 stop bit

9600 baud, 8bit, even parity, 1 stop bit

9600 baud, 8bit, no parity, 1 stop bit

LED Indicators

4 LED indicators on the unit show the conditions CPU heartbeat as well as RS-485 receive and transmit activity.

Configuration Memory

The BARIX X8 contains 256 bytes of non volatile configuration memory (EEPROM) which can be read and (most of it) written via standard Modbus commands.

Connectors

Connector Pin out overview

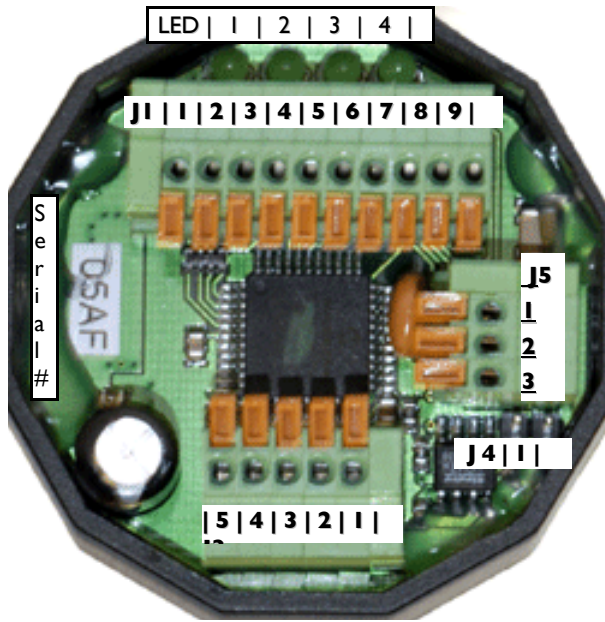

J1 Pin out I/O

Eight I/O signals, signal ground and a regulated 5VDC output are available on J1.

| Pin | Function | Pin | Function |
|-----|------------|-----|------------|
| 1 | Signal GND | 6 | I/O 3 |
| 2 | I/O 7 | 7 | I/O 2 |
| 3 | I/O 6 | 8 | I/O 1 |
| 4 | I/O 5 | 9 | I/O 0 |
| 5 | I/O 4 | 10 | VCC (5VDC) |

For ratings see sections “Inputs”, “Outputs” and “5VDC output” in chapter “Hardware”.

J3 Pin out Power/RS-485

J3 can be used to connect the supply voltage and the RS-485 bus to the unit. An additional “Reference Ground” pin is provided (connected to the Signal ground of the BARIX

X8 via a 100 Ohm resistor) and can be used for grounding applications.



| Pin | Function |
|-----|------------------|
| 1 | Reference Ground |
| 2 | RS-485 A |
| 3 | RS-485 B |
| 4 | VIN (AC or DC) |
| 5 | VIN (AC or DC) |

J4 Pin out GND/Shield Jumper

The Jumper J4 can be used to connect the 3 Shield pins on J5 to “Signal GND” when required.

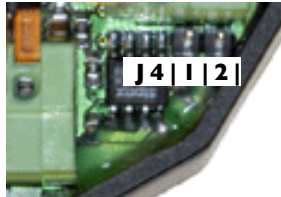

| Pin | Function |
|-----|------------|
| 1 | Signal GND |
| 2 | Shield |

J5 Pin out Shield

J5 provides three pins for connecting shielded cables to the BARIX X8. The three shield terminals are connected to signal ground and to VCC via two 10nF capacitors. (See also J4 jumper for connecting the 3 shield pins on J5 to “Signal GND”)

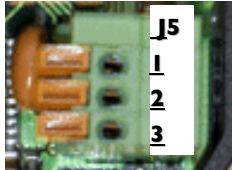

| Pin | Function |
|-----|----------|
| 1 | Shield |
| 2 | Shield |
| 3 | Shield |

LED 1..4 Functions

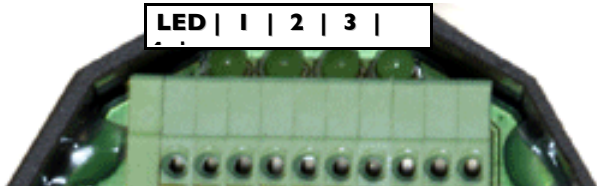

| LED | Function |
|-----|--------------------------|
| 1 | CPU heartbeat |
| 2 | RS-485 receive activity |
| 3 | RS-485 transmit activity |
| 4 | Reserved |

Protocol support

General

The BARIX X8 communicates via the Modbus/RTU protocol over its RS-485 interface. The unit is also configured via writes to Modbus registers. In addition to the actual I/O registers, a 256 byte information area is accessible which contains device type, software version, serial number, the configuration as well as user changeable storage.

Attention:

Writing to registers can take up to 10 milliseconds per address before being confirmed (Modbus acknowledge).

Supported Standard Commands

The following standard Modbus commands are supported by the BARIX X8. All other commands will be answered with an exception code. Due to the limited memory resources of the BARIX X8, the unit cannot receive messages larger than 95bytes and will ignore these (eg. write multiple register commands).

| CMD (hex) | Function |
|-----------|--------------------------|
| 03 (0x03) | read (holding) register |
| 04 (0x04) | read input register |
| 05 (0x05) | write single coil |
| 06 (0x06) | write single register |
| 16 (0x10) | write multiple registers |

Special Commands

The BARIX X8 supports some special, Barix proprietary, commands which have been implemented to ease configuration and facilitate the use of the BARIX X8 in conjunction with non-Modbus systems. These commands are:

| CMD (hex) | Function |
|-----------|--|
| 68 (0x44) | set all outputs on multiple units |
| 69 (0x45) | set configuration using serial number |
| 70 (0x46) | set coil without acknowledge |
| 71 (0x47) | erase firmware, enter download mode with setting 19200,n,8,1 |

Exceptions

The BARIX X8 responds to malformed commands or access violations with the defined Modbus exceptions.

Command 68

The command code 68 (hex 44) can be used to set the outputs of a whole group of BARIX devices very fast and efficiently.

The command is sent via broadcast and can address multiple units, with one byte per device carrying the information for all 8 outputs.

All devices addressed by this command will synchronously set their outputs after the command is completely received. The devices will not send a response to this command.

Command format:

Byte 1 - 0x0 (broadcast address)
Byte 2 - 0x44 (command code)
Byte 3 - ah (first address, hi, always 0)
Byte 4 - al (first address, Modbus address of first device)
Byte 5 - ch (count, # bytes, hi, always 0)
Byte 6 - cl (count, #bytes, lo 8 bit)
Byte 7 - nb (number of bytes following (redundant))
Byte 8...8+nb: data bytes for multiple devices
Byte 8+nb+1: crc1 (crc1 according to Modbus spec)
Byte 8+nb+2: crc1 (crc1 according to Modbus spec)

Example: a command with al=5, cl=nb=4, data 01,02,04,08 will set the outputs on the BARIX X8 with Modbus address 5 to 01 which means output one on, all others off, outputs on the BARIX X8 with the Modbus address 6 to 02 which means output two on, all others off, devices with address 7 and 8 accordingly.

All other devices with Modbus addresses 1..4 and 9..255 are not affected by the command.

Command 69

The command code 69 (hex 45) is used to set a BARIX X8 device which is connected to the bus and whose address is unknown (but serial parameters are correct).

The command can also be sent multiple times with different serial parameters to find the device. The serial number of the device, which can be found on a label on the unit (format xxx-yyy), needs to be inserted into this block to address a specific unit. The block is sent out as a Modbus "broadcast".

Bytes 272, 273, 274, 275 of the Modbus register map (configuration memory positions 16..19) will be written with the provided information if the serial number matches.

Command format:

| | | |
|---------|--------|--|
| Byte 1 | - 0x0 | (broadcast address) |
| Byte 2 | - 0x45 | (command code) |
| Byte 3 | - s1 | (serial number, first part) |
| Byte 4 | - s2 | (serial number, second part) |
| Byte 5 | - s1 | (serial number, first part, repeated) |
| Byte 6 | - s2 | (serial number, second part, repeated) |
| Byte 7 | - c1 | (configuration data for register 272) |
| Byte 8 | - c2 | (configuration data for register 273) |
| Byte 9 | - c3 | (configuration data for register 274) |
| Byte 10 | - c4 | (configuration data for register 275) |
| Byte 11 | - crc1 | (crc1 according to Modbus spec) |
| Byte 12 | - crc2 | (crc2 according to Modbus spec) |

Despite the broadcast addressing, the unit will respond with an acknowledge (containing bytes 1..6 plus crc) !

Command 70

The command code 70 (hex 46) is used to set an BARIX X8 output without a return acknowledgment. The command uses the exact syntax of the 05 (set coil) command, but the BARIX X8 does not send an answer and is immediately ready to receive the next message. The command should be sent addressed to the device address and NOT as a broadcast, otherwise all BARIX X8 units on the bus will react to it.

This command has been added to the BARIX X8 to allow slow systems, which are not Modbus native and cannot

react fast to serial input (like common home automation systems) to set a series of outputs of one or multiple BARIX X8 units without the need to observe Modbus message timeouts, answers etc.

Command 71

The command code 71 (hex 47) is used to erase the firmware of a BARIX X8 device which is connected to the bus and whose address is unknown (but serial parameters are correct). The command can also be sent multiple times with different serial parameters to find the device. The serial number of the device, which can be found on a label on the unit (format xxx-yyy), needs to be inserted into this block to address a specific unit. The block is sent out as a Modbus "broadcast".

After erasing the firmware the device will go into the download mode with serial settings 19200,n,8,1.

Command format:

| | | |
|--------|--------|--|
| Byte 1 | - 0x0 | (broadcast address) |
| Byte 2 | - 0x45 | (command code) |
| Byte 3 | - s1 | (serial number, first part) |
| Byte 4 | - s2 | (serial number, second part) |
| Byte 5 | - s1 | (serial number, first part, repeated) |
| Byte 6 | - s2 | (serial number, second part, repeated) |
| Byte 7 | - crc1 | (crc1 according to Modbus spec) |
| Byte 8 | - crc2 | (crc2 according to Modbus spec) |

Despite the broadcast addressing, the unit will respond with an acknowledge (containing bytes 1..6 plus crc) !

Configuration

Default Parameters

The BARIX X8 is configured via the RS-485 interface using standard Modbus commands.

If the address of the device is not known, it can be reset to default parameters by the following method:

- disconnect the device from power supply
- install a wire between pin 8 and pin 9 on J1

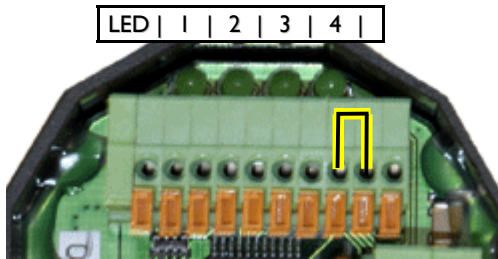

- reapply power to the device

The BARIX X8 will light up all 4 LEDs and the 3rd LED will blink showing that the default parameters are stored in the non volatile memory. No communication is possible at this moment.

- disconnect the device from power supply
- remove the wire between pin 8 and pin 9 on J1
- reapply power to the device

Now the device can be addressed on Modbus address 255 using the following serial settings: 19200 Baud, even parity, 1 stop bit

Connecting I/O

Contacts on inputs

The BARIX X8 features 8 I/Os which are set to work as inputs by default (Reg. 276=00h). The internal pull up resistors are enabled by default (Reg. 273=FFh). Buttons or contact closures can be attached to each input and to signal ground as shown in the schematic below.

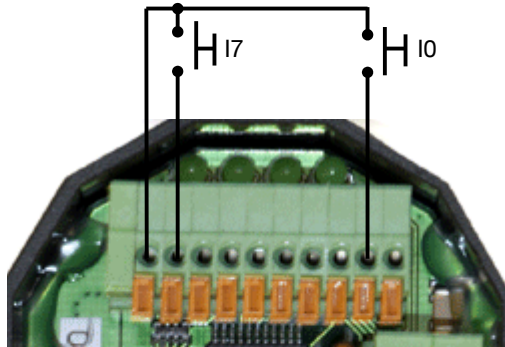

LEDs on outputs

The 8 I/Os of the BARIX X8 can be set to work as outputs (Reg. 276=FFh). LEDs can be attached between each output and the 5VDC source as shown in the schematic below.

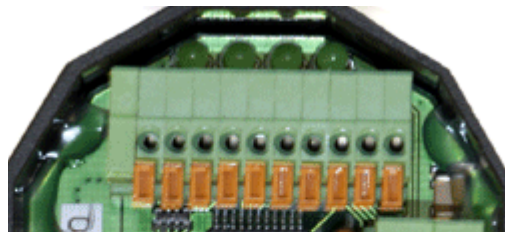
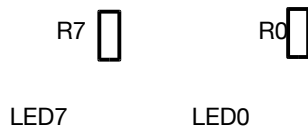

TTL devices on I/O

Each BARI X8 I/O can be set to work either as input or output. External device TTL level I/Os can be attached to the I/Os and to signal ground as shown in the schematic below.

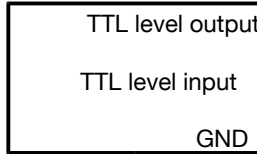

O4 I0

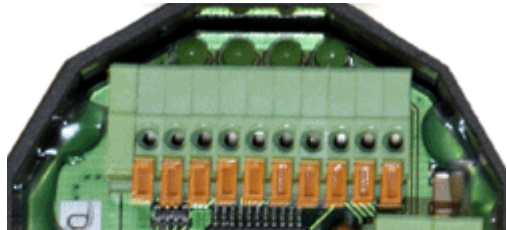

WIEGAND device

One WIEGAND device (keypad, reader) can be interfaced by connecting output D0 to I/O6 and output D1 to I/O7 which are both inputs by default.

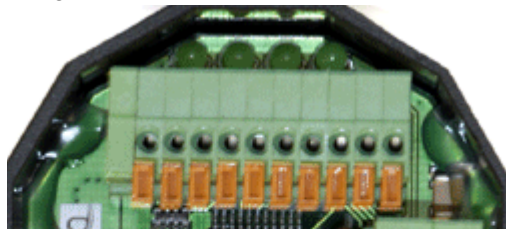
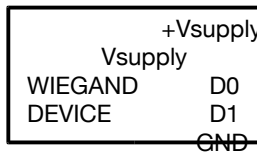

The WIEGAND interface is enabled by setting Bit 6 of register 274 (Reg. 274 OR 40h).

To check if WIEGAND data is available the register 11 has to be read. The lower Byte will contain the amount of Bits received.

If it is 00h then no new data was received. The higher Byte contains a bitmap of found temperature sensors (see next page)

The Bits of the received WIEGAND data are shifted in (from right to left) into the Registers 12 to 16 (5x16=80 bits max):

| Register | 12 | 13 | 14 | 15 | 16 |
|----------|----------|---------------|---------------|---------------|---------------|
| Bit | 1.....16 | 17..... 32 | 33..... 48 | 49..... 64 | 65..... 80 |

Example:

Register 11: 2B1A 1Ah=26 Bits

Register 12: A8DF

Register 13: D8CA

| Register 12 (Word) | | | | | | | | | Register 13 (Word) | | | | | | | | | | | | | | | | | | | | | | |
|--------------------|---|---|---|---|---------------|---|---|---|--------------------|---|---|---|---|---------------|---|---|---|---|---|---|---|---|---|---|---|---|---|---|---|---|---|
| A8 (High Byte) | | | | | DF (Low Byte) | | | | D8 (High Byte) | | | | | 02 (Low Byte) | | | | | | | | | | | | | | | | | |
| 1 | 0 | 1 | 0 | 1 | 0 | 0 | 0 | 1 | 1 | 0 | 1 | 1 | 1 | 1 | 1 | 1 | 0 | 1 | 1 | 0 | 0 | 0 | 1 | 1 | 0 | 0 | 1 | 0 | 1 | 0 | |
| 1 | 2 | 3 | 4 | 5 | 6 | 7 | 8 | 9 | 0 | 1 | 2 | 3 | 4 | 5 | 6 | 7 | 8 | 9 | 0 | 1 | 2 | 3 | 4 | n | n | n | n | n | n | n | n |
| | | | | | | | | | | | | | | | | | | | | | | | a | a | a | a | a | a | a | a | |
| | | | | | | | | | | | | | | | | | | | | | | | 2 | 2 | 2 | 2 | 2 | 2 | 2 | 2 | |
| | | | | | | | | | | | | | | | | | | | | | | | 5 | 6 | | | | | | | |

Note: As the Bits are shifted in from right to left, the Bits in the last Byte are right aligned. The unused Bits can contain old data ! To obtain correct data the last Byte must be masked.

In the above example with 26 Bits the mask for the last Byte is:

$$2^0 + 2^1 = 1 + 2 = 3$$

Now let us mask the data received:

$$CAh \text{ AND } 03h = 02h$$

So the WIEGAND data in this example is in fact:

A8 DF D8 02

The BARIX X8 keeps this data in the registers 12 to 16 and will NOT read further WIEGAND data until register 11 is cleared (Reg. 11 = 00h).

Barix TS Temperature Sensors

Barix offers a rubber encapsulated digital 1-wire temperature sensor (DS18B20) under the product name BARIX TS.

Features: 12 bit resolution, 0.5C accuracy from -10°C to +85°C, wide range: -55°C to +125°C (-67°F to +257°F)



The sensor cable has a green wire (GND) and green wire with a white strip (DQ). Up to 8 Barix TS sensors can be attached to the BARIX X8 as shown in the schematic below:

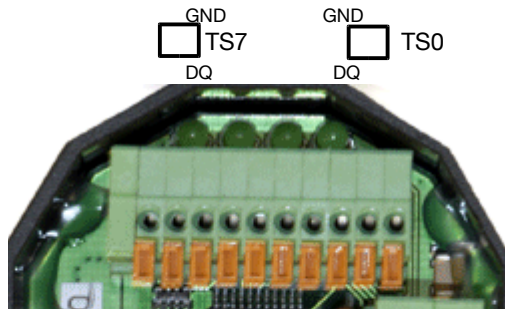

At Power-Up the BARIX X8 is scanning all 8 inputs (I/O0 – I/O7) for attached TS sensors. Each found sensor is represented by the corresponding Bit in the High Byte of register 11:

2 TS sensors attached to I/O0 and I/O7: 1000 0001b = 8100h

The raw data of each TS sensor (typically 12bit resolution, see Dallas data sheet) value is stored in the Modbus registers 3 to 10.

Example code for calculation in degree Celsius:

IF value < 32768 THEN temperature = value / 16.0

ELSE temperature = (value - 65536) / 16.0

ENDIF

Note: Divide by 2 (instead of 16) when using 9bit sensors !

Examples:

Register 3 = 0181h, calculation: $385 / 16 = 24.0625$ °C

Register 3 = FF5Eh, calculation: $(65374 - 65536) / 16 = -10.125$ °C

Connecting a Barix Barionet controller

Power wiring

The Barix Barionet is powered using pin 15 (Vcc) and pin 16 (Vss). In order to power the BARIX X8 connect two wires to the Barix Barionet:

- connect Pin 15 (J6) to Pin 4 (J3) of the BARIX X8 (VIN)
- connect Pin 16 (J6) to Pin 5 (J3) of the BARIX X8 (VIN)

Attention: do not use a AC power supply when connecting the BARIX X8 to Barionet ! Use a DC power supply instead !

RS-485 wiring

Connecting the RS-485 bus is simple as the RS-485 signals are available on J7 which is also a detachable screw terminal block:

RS 422/485

6 5 4 3 2 1



| Pin | 485 |
|-----|---------------|
| 1 | Reference GND |
| 2 | Not used |
| 3 | Not used |
| 4 | RS-485 A |
| 5 | RS-485 B |
| 6 | Reference GND |

- connect Pin 4 (J7) to Pin 2 (J3) of the BARIX X8 (RS-485 A)
- connect Pin 5 (J7) to Pin 3 (J3) of the BARIX X8 (RS-485 B)

When communication problems occur two measures can be taken to improve the RS-485 signal quality.

Reference wire

When using two separate power supplies a third wire should be used to ensure a common voltage level :

- Connect Pin 1 or Pin 6 (J7) to Pin 1 (J3) of the BARIX X8

RS-485 termination

When the two devices need to be connected over a long distance both sides of the cable should be terminated using a 100 Ohm

resistor to suppress signal reflections:

- Connect a 100 Ohm resistor between Pin 4 and Pin 5 (J7) directly at the terminals of the Barionet controller

- Connect a 100 Ohm resistor between Pin 2 and Pin 3 (J3) directly at the terminals of the BARIX X8

Modbus Register Map

The BARIX X8 implements some registers in the Modbus address space. Access to unimplemented locations generates an exception.

The Modbus address space is divided into multiple address maps, all 65536 registers in size. The BARIX X8 implements the “coils” (output bits) and the “registers” (16 bit).

Reading back discrete (1bit) values is not supported.

Attention: All Modbus addresses count from 1, while the protocol addresses start at 0. This documentation uses the Modbus register number – in the protocol the address must be one less !!

Example:

Modbus register 1 is addressed in Modbus/RTU as “0”.

Live I/O

The state of the outputs can be set/reset using “set coil” and “write register” commands. In addition, the state of the outputs can be read back using the “read register” command.

In the “coil” address map, only positions 1..8 (Modbus/RTU addresses 0..7) are populated in the BARIX X8, which are mapped to outputs 1..8. Write access to any other address is prohibited.

In the “register” address map, the outputs can be written simultaneously by accessing register 1. Bit 0 is output 1, bit 1 is output 2, ... bit 7 is output 8.

The state of the inputs 0 to 7 can be read using the “read input register” command on register 2 (see corresponding Bits 0 to 7).

The analog values (10bit res. [0..1023] / sampling rate 62.5 Hz) of each input can be read using the “read input register” command on register 3 (input 0) to 10 (input 7).

When a Barix TS temperature sensor is connected the

Configuration Data

analog voltage is replaced by the temperature (for each attached sensor)!

All configurable parameters are accessible using standard Modbus read/write commands to registers.

The configuration information area is 256 bytes, which is accessible as registers 257..512 in the Modbus memory map.

Of each configuration register only the lower 8 bits (Byte not Word) are used.

The first 16 bytes of the configuration registers are “one-time” writable only – after setting these registers to a value not equal to 255 (hex 0xff) they can not longer be changed. In the first 8 bytes, Device type, software version, and serial number are stored (ID registers). The remaining 8 bytes can be used by the installer to write permanent information (like shipping date, system ID, location etc).

The next 16 bytes are used as configuration registers.

The remaining registers (290..512) can be used to store user information.

ID registers

Device information such as device ID, software version etc can be accessed using standard register read commands. This information is read-only and cannot be overwritten. The information is accessible using standard reads from addresses 257..264.

Register 257: set fixed to “0xB2” (stands for BARIX X8)

Register 258: software version, 06 at the time of printing.

Register 259: first part of the serial number (byte)

Register 260: second part of the serial number (byte)

Register 261..264 are reserved for future use by Barix

Register 265..272 are usable as one-time writable storage by the installer or controlling software.

Configuration registers

Device configuration can be set and read using standard Modbus commands. The BARIX X8 will reset its actual communications parameters to these values anytime it does not receive valid host communication for more than 5 seconds.

Register 273: Pull up resistor yes/no (1=yes, 0=no)

Register 274: Serial interface speed "Bit 0":
0 selects 19200 baud / 1 selects 9600
baud

WIEGAND support "Bit 6":
0=disabled / 1=WIEGAND support
enabled

Serial interface parity " Bit 7":
0=Even parity / 1= No parity.

Register 275: This register holds the Modbus address of the
the unit.

Register 276: I/O function setting (1=output, 0=input)

Register 277..289: Reserved for future
enhancements.

Complete Register Map

Detailed “register” map – again – please note that the protocol address in Modbus/RTU is the register number less one !!

| Register | Function | Access |
|------------|--|--------|
| 1 | Live I/O (Byte, output state bit 0..7) | R, W |
| 2 | Live I/O (Byte, input state bit 0..7) | R |
| 3 | Live I/O (10bit analog value input 0 or digital temperature input 0) | R |
| 4 | Live I/O (analog/temperature inp. 1) | R |
| 5 | Live I/O (analog/temperature inp. 2) | R |
| 6 | Live I/O (analog/temperature inp. 3) | R |
| 7 | Live I/O (analog/temperature inp. 4) | R |
| 8 | Live I/O (analog/temperature inp. 5) | R |
| 9 | Live I/O (analog/temperature inp. 6) | R |
| 10 | Live I/O (analog/temperature inp. 7) | R |
| 11 | High Byte: Bitmap of TS temperature sensors found at Power-Up Low Byte: Received WIEGAND Bits | R, W |
| 12..16 | WIEGAND data shift registers | R, W |
| 17..256 | Reserved, not accessible | - |
| 257 | Device type (hex 0xB2) | R, WO |
| 258 | Firmware version | R, WO |
| 259 | Serial number 1 st part | R, WO |
| 260 | Serial number 2 nd part | R, WO |
| 261..264 | reserved | R, WO |
| 265..272 | One-time writable for installer | R, WO |
| 273 | Pull up resistor setting (bit 0..7) | R, W |
| 274 | Serial interface mode / WIEGAND | R, W |
| 275 | Modbus address | R, W |
| 276 | Input / Output selection (bit 0..7) | R, W |
| 277..289 | reserved | R, W |
| 290..512 | Memory for installer/software use | R, W |
| 513..65536 | not accessible | |

Access explained:

R stands for “Read”, W for “Write”, WO for “Write Once”

Complete Coils Map

Detailed “coils” map – please note that in the protocol, address in Modbus/RTU is the coil number less one !!

| Coil | Function |
|----------|-------------------------|
| 1..8 | Output 0..7 |
| 9..65536 | Reserved, do not access |

Technical specifications

| | |
|----------------------------------|--|
| CPU | PIC 16F877A, 20MHz clock frequency |
| I/Os | 8 independent inputs/outputs (TTL level) or analog inputs or Dallas 1-wire temperature sensor inputs (Barix TS) Digital inputs: debouncing filter 48ms (active @ $\leq 2.5\text{VDC}$) Analog inputs: 0..5VDC sampling rate 62.5 Hz(16ms), 10bit resolution Outputs: sink/source 20mA max. See "5VDC output" for total current limitations ! |
| 5VDC output | Regulated 5 VDC source: current of 5VDC and all used outputs combined should not exceed 24mA @ 30VDC Vin, 32mA @ 24VDC Vin, 85mA @ 12VDC Vin or 100mA @ Vin $\leq 11\text{VDC}$. |
| I/O, RS-485/Power, shield | 3 spring contact connector blocks for wires AWG28 - AWG16 / 0.08 - 1.3 mm ² |
| Host Interface | RS-485: 9600 and 19200 Baud, 8 bit, even or no parity. |
| Power Supply Requirements | 12 to 24 VAC / 9 to 30 VDC 1 Watt max. |
| LED Indicators | 1 LED for CPU heartbeat 2 LED for active traffic indication 1 LED reserved |
| Case | High quality plastic, 34 grams, Case diameter 2"/52mm, height 0.9"/23mm 2 removable mounting brackets width 0.36"/9 mm, length 2.76"/70mm, 0.2"/5mm holes (center distance 2.36"/60mm) |
| Misc. | Internal connector for shield to ground jumper |
| Environmental conditions | Temperature: 32 to 104° F / 0 to 40° C Humidity: < 70% relative humidity non-condensing |
| Conformit | FCC A and B, CE A and B Emission EN60730-1:2000 (Class B) Immunity EN60730-1.2000 |

©2006 Barix AG, Zürich, Switzerland.

All rights reserved.

The newest information about our devices and the latest version of this manual is available via download from our website, www.barix.com.

We explicitly reserve the right to change and improve the product without notice.

All trademarks mentioned belong to their respective owners.

Barix, BARIX X8 and Barionet are trademarks of Barix AG, Switzerland and are registered in certain countries.

Barix AG

Barix Technology Inc.

Seefeldstrasse 303

2182 Helena Rd.

8008 Zürich

St. Paul, MN 55128

SWITZERLAND

USA

Phone: +41 43 433 2211

Phone: (866) 815-0866

Fax: +41 44 274 2849

Fax: (209) 755-8435

Internet

web: www.barix.com

email: sales@barix.com

support: support@barix.com